

SECTION 4.0 - DESIGN REQUIREMENTS

4.1 GENERAL DESIGN REQUIREMENTS

Except where This Guide provides otherwise, design detail, workmanship, construction specifications, and materials shall be in accordance with the following (in the following order of precedence):

1. Clackamas County Service District No. 1 – Standard Sewer Specifications and Standard Drawings.
2. Current APWA Standard Specifications and Drawings for Public Works Construction published by the Oregon Chapter of the American Public Works Association.
3. Standard Detail Drawings adopted by the Clackamas County Department of Transportation and Development.
4. Current Clackamas County Storm Water Quality and Erosion/Sedimentation Control policies.
5. Clackamas County Road Use Ordinance.
6. ODOT Standard Specifications.
7. AASHTO – (American Association of State Highway and Transportation Officials).

It is the Engineer's responsibility to comply with other applicable federal, state, and local regulations, particularly with respect to wetland regulations and other development requirements.

Performance Standards – Sanitary sewer system design shall meet the policies and guidelines of OAR chapter 340 Division 52 Section 0020 and its updates.

Design shall comply with Oregon Department of Environmental Quality sewer design guidelines.

Sanitary sewer system capacity shall be designed for ultimate development density of the tributary area. The system shall allow for future system extension and for future development.

Sanitary sewers shall be designed to remove by gravity the domestic sewage and industrial wastes from basements of houses, commercial or industrial buildings, and all public and private establishments where possible. Pump stations will be reviewed on a case by case basis (See Section 2.6).

Storm water, including street, roof, or footing drainage, shall not be discharged into the sanitary sewer system but shall be removed by a system of storm drains or by some other method separate from the sanitary sewer system.

As a condition of sewer service, all developments will be required to provide public sewers to serve adjacent upstream parcels in order to provide for an orderly development of the drainage area. This shall include the extension of sewer mains in easements across the property to adjoining properties and across the street frontage of the property to adjoining properties when the main is located in the street right-of-way.

This shall include trunk sewers that are oversized to provide capacity for upstream development.

4.2 SANITARY SEWER REQUIREMENTS

4.2.1 PIPE MATERIALS AND SIZE

All public sanitary sewers shall be constructed with material as specified in the appropriate section of the District's Standard Sewer Specifications. Where required for added strength, Class 52 Ductile Iron pipe or C900 PVC shall be used. PVC pipe and fittings not requiring extra strength shall conform to ASTM- D-3034, SDR 35.

Private sanitary sewers shall meet the appropriate sections of the Uniform Plumbing Code (UPC).

All sanitary sewer main lines shall be a minimum diameter of eight inches (8") and shall begin at a manhole and shall terminate at a manhole.

4.2.2 DESIGN SEWAGE FLOW

Design flows shall be determined by using the factors of the specific Master Plan, if available, in which the development is situated.

In the absence of Master Plan and flow data or other reliable information, the following factors may be assumed:

Per Capita Peak Hourly Flow: 400 gpcd (lateral sewers)¹

It is recommended that design calculations include estimates of average maximum and minimum daily flows. The submission of design calculations will not ordinarily be required, but designers should be prepared to substantiate pipe sizes, layout, population estimates, land uses, or other design assumptions.

These factors may be used to estimate the peak daily flow which includes an allowance for infiltration.

Design capacity of lateral and trunk sewers shall be designated on the following basis:

1. Lateral Sewers – Design capacity shall be based on sewer flowing two-thirds (2/3) full.
2. Trunk Sewers – Design capacity shall be based on sewers flowing full, without head.

4.2.3 SLOPE AND VELOCITY DESIGN

4.2.3.1 SLOPE DESIGN

Minimum design slope shall be as follows:

Inside Pipe Diameter (inches)	Minimum Design Slope (ft./ ft.)
8	0.0045

¹ Per capita peak hourly flows are the sum of peaked average daily domestic flows and infiltration inflow. The per capita peak hourly flows for trunk sewers must be computed for each case because of variable peaking factors.

10	0.0033
12	0.0027
15	0.0020
18	0.0017

Design slopes for larger pipes will be determined on a case-by-case basis. In general, slopes greater than those shown above are desirable and are particularly recommended where the main will not be extended further and there are few connections.

Minimum as-built slopes shall be as follows:

Inside Pipe Diameter (inches)	Minimum As-Built Slope (ft./ ft.)
8	0.0040
10	0.0028
12	0.0022
15	0.0015
18	0.0012

Minimum as-built slopes are based on slopes required to produce a mean velocity, when flowing full or half full, of at least two (2) feet per second (fps), based upon Manning's "n", the coefficient of roughness, valued at not less than 0.013. Pipe installed at slopes less than the minimum as-built will not be accepted.

The Engineer shall design systems using the optimum design slopes in most cases. However, the District reserves the right to require design slopes down to the minimum as-built slopes when flatter slopes are required to serve the basin.

Slopes slightly less than those shown above may be considered if substantial justification can be demonstrated that there will be sufficient flows present to scour the pipe at 2 ft/sec from 8:00am to 8:00pm. Average flows of 400 gal/day generated from each dwelling unit shall be used to determine upstream contributions.

In general, slopes greater than those shown above are desirable and are particularly recommended on the upper ends of sewers. The preferable slope shown shall be used for the last 400 feet of non-extendable sewers.

1. Anchor Walls.

Sanitary sewers on slopes in excess of 20 percent shall be secured through the use of concrete anchor walls. Spacing for anchors shall be as follows:

Minimum Anchor Spacing	
Slope (%)	(Center to Center)
20-34	35 feet
35-50	25 feet
51+	15 feet or Concrete Encasement

4.2.3.2 VELOCITY DESIGN

Where flow velocities greater than fifteen feet (15') per second are attained, the pipe material shall be ductile iron and special provision shall be made to protect manholes against erosion and displacement by shock. This may be accomplished by installing one additional manhole to decrease the slope or to split a 90° horizontal direction change into two (2) 45° incremental changes. The flow must be contained in the channel.

4.3 ALIGNMENT AND COVER

Curved alignments in sanitary sewers are not permitted.

4.3.1 RIGHT-OF-WAY LOCATION

Sanitary sewer lines shall be straight, and located five feet (5') north or west from the right-of-way centerline. All changes in direction of pipe shall be made at a manhole. Sewers shall be located in the street right-of-way. If streets have curved alignments, the center of the manhole shall not be less than six feet (6') from the curb face on the outside of the curve nor less than six feet (6') from the curb face on the inside of the curve. Do not place manholes in the wheel path.

4.3.1.1 EASEMENTS

Sewers in easements will be allowed only after all reasonable attempts to place the lateral sewer in the right-of-way have been exhausted.

When it is necessary to locate sewers in easements, the sewer shall be centered in the easement, and the conditions of the easement shall be such that the easement shall not be used for any purpose which would interfere with the unrestricted use for sewer main purposes.

Sewers placed in easements along a property line shall have the easement centered on the property line, the sewer shall be offset twenty-four inches (24") from the property lines.

Easements for lateral sewers shall have a minimum width of fifteen feet (15'). Easements for trunk sewers shall have a minimum easement width of 20 feet (20').

Sewers with more than eight feet (8') of cover and/or inside diameters 24 inches (24") or combined with storm sewers will require wider easements. A slope of one horizontal to one vertical from the sewer invert to ground surface will be used to determine easement width. Easement widths shall vary from the fifteen foot (15') minimum by five foot (5') increments; for instance, 15, 20, 25 feet.

Easement locations for public sewers serving a Planned Unit Development, apartment complex, or commercial/industrial development shall be in parking lots, private drives, or similar open areas which will permit unobstructed vehicle access for maintenance by District personnel.

Common easements for other utilities will be reviewed on a case-by-case basis. Separation of utilities must meet Oregon State Department of Environmental Quality (DEQ) and Oregon Department of Health requirements.

All easements must be furnished to the District for review, approval and recording. Easements granted to the District via Plat shall be labeled as a public sanitary sewer and storm drainage easement.

4.3.2 RELATION TO WATER LINES AND OTHER UTILITIES

No sanitary sewer shall be less than fifty (50) feet from any well, spring, or other source of domestic water supply unless approved by the District. All sanitary sewers or parts thereof which are located within fifty (50) feet of any source of domestic water supply shall be constructed of ductile iron water pipe with watertight joints, or of other approved pipe.

The basic separation requirements apply to all gravity and pressure sewers of twenty-four (24) inch diameter or less. Larger sewers may create special hazards because of flow volumes and joint types, and accordingly require additional separation requirements. The special construction requirements given are for the normal conditions found with sewage and water systems. More stringent requirements may also be necessary in areas of high ground water, unstable soil conditions, etc. Any site conditions not conforming to conditions described in this section will require assessment and approval by the District.

1. No Special Requirements (Parallel).

A minimum horizontal separation of ten (10) feet between sanitary sewers and any existing potable water lines, and a minimum vertical separation of eighteen (18) inches between the bottom of the water line and the crown of the sewer, shall be maintained. The distance shall be measured edge to edge.

2. Justification Required (Parallel).

When conditions prevent the separations described above, a sewer may be laid closer than ten (10) feet horizontally or eighteen (18) inches vertically to a water line, provided:

It is laid in a separate trench from the water line.

The elevation of the crown of the sewer line must be at least eighteen (18) inches below the bottom of the water line. When this vertical separation cannot be obtained, the sewer shall be constructed of materials and joints that are equivalent to water main standards of construction and shall be pressure tested to ensure watertightness prior to backfilling. Adequate restraint should be provided to allow testing to occur.

- If sewers must be located in the same trench as a potable water line, special construction and mitigation is required. Both water lines and sewer lines shall be constructed with a casing pipe of pressure-rated pipe material designed to withstand a minimum static pressure of one-hundred fifty (150) psi. The water line shall be placed on a bench of undisturbed earth with the bottom of the water pipe at least eighteen (18) inches above the crown of the sewer, and shall have at least five (5) feet of horizontal separation at all times.

3. Vertical Separation (Perpendicular).

Sewer lines crossing water lines shall be laid below the water lines whenever possible to provide a separation of at least eighteen (18) inches between the invert

of the water line and the crown of the sewer. See Special Conditions if this is not possible.

4.3.2.1 SPECIAL CONDITIONS.

When conditions prevent a vertical separation as described above, construction shall be used as follows:

1. Gravity Sewers Passing Over or Under Water Lines

These gravity sewers shall be:

Constructed of material described in the table below.

Standard gravity-sewer material encased in concrete or in a one-quarter (¼) inch thick continuous steel, ductile iron, or pressure rated PVC pipe with a dimension ratio (DR) (the ratio of the outside diameter to the pipe wall thickness) of eighteen (18) or less, with all voids pressure-grouted with sand-cement grout or bentonite.



The length of sewer pipe shall be centered at the point of crossing so that the joints will be equidistant and as far as possible from the water line. The sewer pipe shall be the longest standard length available from the manufacturer.

Standard Pipe Material

Type of Pipe	AWWA (ASTM) Standard		
	Pipe	Joint	Fittings
Ductile Iron	C 151 and C104	C111	C 110
Polyvinyl-Chloride	C 900*	(D 3139 and F 477)	C 110
Concrete Cylinder	C 303		
HDPE 3408	C906	Fused per C 906	C 906

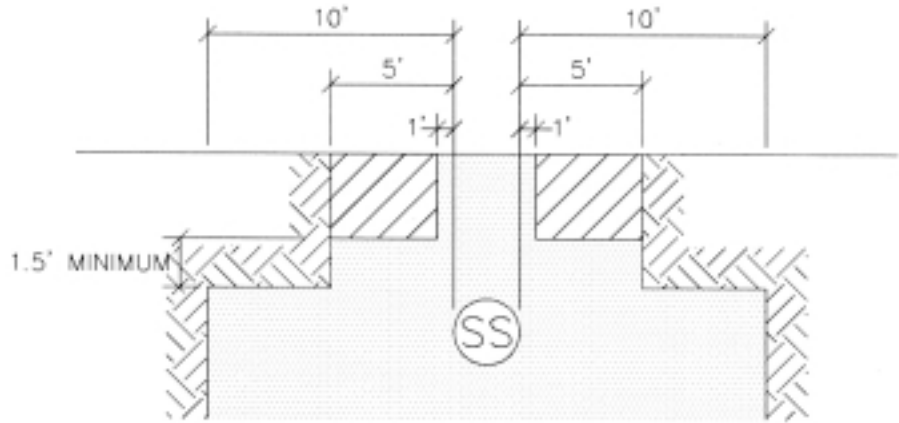

* Pipe specifications are C900 for pipe up to 12 inches in diameter; C905 for pipe more than 12 inches in diameter.

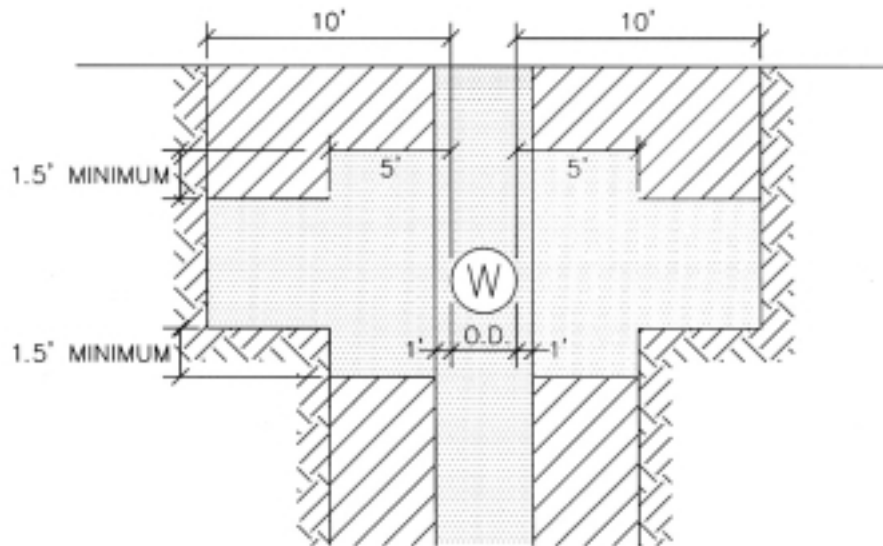

WATER LINE ZONES	
	PROHIBITED INSTALLATION
	JUSTIFICATION REQUIRED
	NO SPECIAL REQUIREMENTS

SEPARATION OF PARALLEL SEWER-WATER LINES



SEWER LINE ZONES	
	PROHIBITED INSTALLATION
	JUSTIFICATION REQUIRED
	NO SPECIAL REQUIREMENTS

SEPARATION OF PARALLEL WATER-SEWER LINES

2. Water Lines Passing Under Gravity Sewers

Water Lines shall be protected by providing:

A vertical separation of at least 18 inches (18") between the invert of the sewer and the crown of the water line.

Adequate structural support for the sewers to prevent excessive deflection of joints and settling on and breaking of the water lines.

The length of sewer pipe shall be centered at the point of crossing so that the joints will be equidistant and as far as possible from the water line. The sewer pipe shall be the longest standard length available from the manufacturer.

A water line casing equivalent to that specified in Section 1 above.

Written approval from local water authority.

4.3.3 RELATION TO STREAMS AND DRAINAGE CHANNELS

Sewers crossing streams or drainage channels shall be designed to cross the stream as nearly perpendicular to the stream channel as possible and shall be free from change of slope

The top of all sanitary sewers entering, crossing or adjacent to streams shall be at sufficient depth below the natural bottom of the stream bed to protect the sewer line. One foot (1') of cover is required where the sewer is in rock, three feet (3') of cover is required in other materials and a minimum of 6 inches (6") cover is required in paved channels.

Pipe material shall be ductile iron with an eighteen foot (18') length of pipe centered on the stream or drainage channel centerline. The ductile iron pipe shall extend to a point, where a one-to-one slope, which begins at the top of the bank and slopes down from the bank away from the channel centerline, intersects the top of the pipe.

Sewers located parallel to streams shall be located outside of the stream bed. All manhole covers, at or below the 100 year flood elevation shall be watertight.

All construction shall comply with the latest regulations as determined by the Corps of Engineers and Division of State Lands for removal and filling in waterways. In addition, all requirements for the Endangered Species Act must also be met. The activities authorized by the approval of the request in this application may be subject to other laws not addressed in this process.

4.3.4 MINIMUM COVER

All sewers shall be laid at sufficient depth to drain building sewers, protect against damage from traffic and afford protection from other utilities. Sufficient depth shall mean the cover from the top of the pipe to finish grade at the sewer alignment.

Under normal conditions, sewers shall be placed with a minimum cover of eight feet in roadways and six feet of cover in easements.

In hillside subdivisions, sewers shall be placed in the street at a depth sufficient to drain building sewers on the low side of the street.

Where less than three feet of cover is proposed, installation of Class 52 ductile iron pipe or equivalent is required. Submit a request in writing along with the required documentation to the District when either of the following circumstances exists:

1. Underlying rock strata encountered: Submit a soils report from a registered geotechnical engineer including a plan and profile certifying bed rock exists within three feet (3') of the undisturbed ground surface at all investigated alignments. See note below for additional documentation.
2. Utility conflicts: Submit a plan and profile of the conflict showing pipes/conduits/etc., which results in the depth of cover to be reduced to three feet or less. See note below for additional documentation.

Note: Additional documentation for 1 and 2 includes submittal of sufficient documentation to reasonably insure that adjacent property building sewers can still drain by gravity for any future extensions.

4.4 STRUCTURES

4.4.1 CLEANOUTS

Cleanouts will not be approved as substitutes for manholes, except temporarily at the upper end of a mainline sewer that will be extended on the same slope and alignment during the next construction phase. The cleanout shall be removed and the sewerline shall be extended meeting all design criteria in This Guide. All cleanouts will be reviewed on a case-by-case basis.

4.4.2 MANHOLES

4.4.2.1 LOCATION

Manholes shall be placed at the following locations:

1. At every change in slope, alignment or size of pipe.
2. At each intersection or junction of a sewer line.
3. Where practical, manholes shall be located at street intersections.
4. At the upper end of all sewers, except as provided under subsection 4.4.1.
 - a) adjacent to the radius point of a cul-de-sac which has three (3) or more parcels of land fronting on the cul-de-sac.
 - b) In front of the last property or lot being served, ten feet (10') past the common lot line of the adjoining parcel served.

5. At intervals of 500 feet (500') or less. Deviation from this requirement shall be reviewed on a case-by-case basis for approval, considering whether maintenance equipment can adequately service the proposed sewer line.
6. At service connections of eight inches (8") or larger.

Manholes shall not be placed in the following locations:

1. In the wheel path, curb or gutter.
2. Behind the curb line. Placement of manholes behind the curb shall be reviewed on a case-by-case basis for approval. Consideration shall be given to those sewer lines which already exist behind the curb.

4.4.2.2 SLOPE OF MANHOLE CHANNEL

Standards for elevation differences at manholes have been established to compensate for normal energy losses and to prevent surcharging of a sewer by a larger sewer. For purposes of slope calculation and for establishing elevation differences, the elevations are given at the intersection of the sewer centerline (usually the center of the manhole). The intent of this subsection is to prevent the difference in pipe inverts at the manhole wall on steep sewers from exceeding one foot (1'), which renders it impossible to insert a TV camera into the outfall line if the average slope exceeds twenty-five (25) percent. The rules for elevation differences at manholes are:

1. The crowns of incoming sewers shall be at least as high as the crown of the outgoing sewer.
2. The drop across the manhole shall normally be two-tenths (0.20) of a foot unless otherwise permitted by the District.
3. Slope shall be determined to the center of the manhole. The average between any inlet Slope (Si) and outlet Slope (So) in percent across the manhole shall not exceed 25 percent.

$$\frac{S_i + S_o}{2} = \text{less than 25 percent (feet per 100 feet)}$$

The above formula will limit the difference between the inlet and outlet inverts measured at the manhole walls from exceeding one (1) foot for an average manhole diameter of four (4) feet. This formula applies to sewers with a slope in excess of nineteen (19) percent.

Generally, a vertical offset in slope exceeding twenty-five hundredths (0.25) of a foot will not be permitted. Exceptions will be the following:

- A. When a smaller diameter connects to a larger diameter sewer.
- B. When a grade conflict exists with an existing utility, the maximum vertical drop may be one (1) foot or as approved.
- C. When a vertical drop greater than two (2) feet is approved, an outside drop must be installed.

4.4.2.3 DROP MANHOLES

Outside drop assemblies shall be provided for pipe lines twelve (12) inches in diameter and smaller when entering a manhole at a distance of more than twelve (12) inches above the invert of the outlet line. Inside drops into manholes shall

not be allowed. The vertical displacement shall be measured at the inside manhole walls and not the manhole centerline. Larger pipe lines shall be introduced into the manhole at the manhole invert.

SPECIAL NOTE: Drop manholes shall only be used in extreme cases of slope difference between existing and proposed sewer lines or when very special conditions exist such as a conflict with existing facilities which cannot be relocated.

4.4.2.4 RIM ELEVATIONS OF MANHOLES

In areas used by vehicles (paved or unpaved streets) the manhole rim elevation shall match the finished grades. In other areas the height of the manhole rim will normally be six (6) inches above finished grade, highwater mark, or above the top of future fill areas.

4.4.2.5 DESIGN AND SIZE

All manholes shall be a minimum of forty-eight (48) inches inside diameter. All manholes shall have a minimum twelve (12) inch ledge in the base.

4.4.2.6 CONNECTIONS

Connections to existing manholes shall be designed with the following guidelines:

1. No pipe shall enter an existing manhole where the angle between the incoming flow and the outgoing flow is less than 90°. When the horizontal deflection angle to an existing sewer is greater than 90°, two (2) manholes shall be installed. Spacing of such manholes shall be a minimum of ten feet (10') outside to outside.
2. Manhole walls shall be core drilled (not jack hammered) for new lines.
3. New lines should enter the existing manhole at the top of the shelf.
4. The flow entering the manhole shall follow a smooth unobstructed concrete channel transition from the inlet pipe into the main channel.
5. When the invert of the connecting pipe cannot be located on the manhole shelf, the contractor will be required to construct an outside drop with the inlet pipe invert being located at the manhole shelf. The minimum height for the outside drop shall be two feet above the manhole shelf. The flow entering the manhole will follow a smooth concrete channel transition from the inlet pipe into the main channel.
6. Where the new incoming pipe is required to enter below the shelf of the manhole, the inlet pipe will not enter below a point where the crown of the new inlet pipe is below the crown of the outlet pipe. The base of the manhole will be rebuilt if damaged in this process.

4.4.2.7 Anticipated Future Extensions

All manholes from which future sewer line extensions are anticipated, shall be channeled and have a boot and plug installed in the direction of the anticipated sewer main extension. Boots shall be located at least 0.20 feet above the lowest invert in the manhole. Channels shall be formed in the manhole base to accommodate the future flow. Stub outs shall only be installed in manholes

when permitted by the District. Pipe stubs shall be a minimum of eight inches (8") in size or as permitted by the District and shall be of an approved type of pipe. Stubs shall protrude a maximum of fifteen (15) feet without a temporary cleanout unless otherwise permitted by the District and shall be plugged with a standard watertight plug or cap. An exception to this section may be made by the District if the direction of the new line cannot be established at the time of construction.

4.5 SEWER SERVICE CONNECTIONS AND PRIVATE SYSTEMS.

All service connections to the District's lines shall be made by means of a manufactured tee connection. No wye or grouted connections will be allowed. No service connection shall be larger than the mainline it connects to. Service connections 8" (eight inches) or larger require a manhole connection. Service connections shall be installed to the limits of the Public Utility Easement, right of way or easement line. Service connections shall be terminated with a watertight cap or plug. A 2x4 painted green extending one foot above finished grade shall mark the termination location. Tees for service connections shall be located no closer than five feet (5') to manholes and near the low side of lots.

4.5.1 DIRECT SEWER SERVICE CONNECTION

All sanitary facilities connected to the District sewerage system shall be directly connected thereto without any intervening private sewage treatment system except for permitted Industrial Pretreatment facilities.

4.5.2 SEPARATE SERVICE CONNECTION AND BUILDING SEWER

1. A separate and independent service connection shall be provided for each tax lot or lot of record, except as provided in CCSD#1 Rules and Regulations.

4.5.3 RESTRICTED CONNECTIONS

No person shall connect any roof, surface, foundation, footing, or exterior area drains to any service connection, building sewer, or building drain which is connected to the District sanitary sewer system.

4.5.4 USERS REQUIRING PUMPING FACILITIES

If the building is below the available gravity sewer line, the owner or user shall install pumping facilities in accordance with the uniform Plumbing Code. The owner or user will be required to enter into an agreement with the District regarding the terms and conditions of connection and pumping. Flows from pumped facilities shall enter the Public Sewer by means of a gravity service connection. District to review all pumped connections on a case-by-case basis.

4.5.5 MATERIALS

The pipe and joint materials permitted for service connections are listed in the table below:

PIPE AND JOINT MATERIALS PERMITTED FOR SERVICE CONNECTIONS				
Type of Pipe	Minimum Diameter	Pipe Specifications	Type of Joint	Joint Specifications
Cast iron water pipe	4"	ASA A 21.6 (Class 22)	Tyton joint	ASA a 21.11
Cast iron soil pipe service weight bell and spigot	4"	ASTM A 74-69	Neoprene inserted gasket	ASTM C-564-70
Poly vinyl chloride pipe (PVC)	4"	ASTM D-3034-74 (SDR 35)	Elastomeric gasket	ASTM D-3212

Abbreviations: ASTM – American Society for Testing Materials
 ASA – American Standards Association

NOTE: All couplings, adapters, etc., used to connect dissimilar pipe materials together shall be approved by the District.

4.5.6 TAP-IN CONNECTION

District personnel shall tap all District lines up to eighteen (18) inches in diameter. Lines greater than eighteen (18) inches in diameter shall be taped by private contractor at owners expense and inspected by District personnel. After applicable fees have been paid the installer shall excavate to and completely expose the public sewer at the designated point of connection. The District shall tap the sewer and install the 4-inch or 6-inch connection fitting at the owner's expense. In the event that the installer fails to comply with all state and federal safety codes applicable to the work, the District shall not make the tap or perform any inspection.

4.5.7 SLOPE AND ALIGNMENT

The minimum slope for 4" (four inch) service connection pipes shall be 2.00 percent (¼ inch per foot) except that for unusual conditions, a slope of 1.00 percent (1/8 inch per foot) may be approved by the District. Maximum slope shall be a 100 percent slope (45 degrees) with 1/16 or 1/8 bends inserted to provide proper slope for pipe. All turns in alignment of the pipe or changes in the slope of the pipe shall be made with manufactured fittings. No 90 degree bends will be allowed.

4.5.8 MINIMUM DEPTH

The minimum depth at the property line crossing for service connections shall six (6) feet below the surface elevation at the centerline of the road if the public sewer lies within a road or the centerline of the public right-of-way or sewer easement if the public sewer does not lie in a road. Service connections which cannot be laid at the required depth shall be protected as approved by the District.